

GET IT RIGHT

3. DPC's in Clay Brickwork

The provision of a Damp Proof Course (DPC) in a building, or free standing wall, is intended to provide a barrier to the passage of water from the exterior to the interior of the building, from the ground to the structure, or from one part of the structure to another. This passage of water may be horizontal, upwards, or downwards, and if measures to counteract it are not taken with care, dampness may result and the effectiveness of thermal insulation may be reduced. This 'Get It Right' outlines the basic principles of correct DP installation and application, in both solid and cavity forms of masonry construction.

1. Materials for Damp Proof Courses.

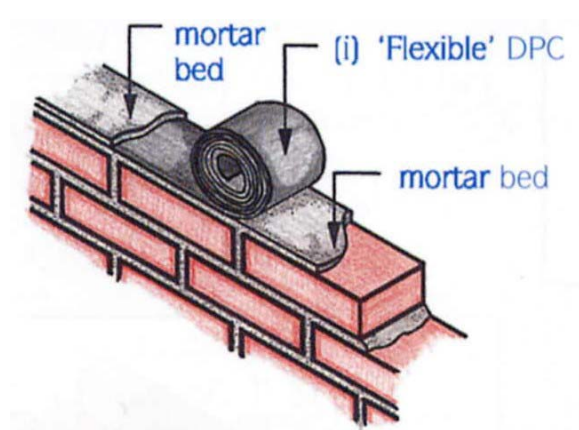

(i) Flexible – the most common types, bitumen polymer, pitch polymer or polythene are supplied in a range of widths including 110, 220 and 300mm. A flexible type DPC must be 'sandwiched' within the mortar joint and have ability to adhere to the mortar.

(ii) Rigid – two courses of engineering bricks bedded in a designation (i) mortar, give stability in free standing walls. (refer to BS EN 771-1 for properties for bricks that can be used for DPC's.) Rigid DPC's are suitable to resist rising damp but not the downward flow of water.

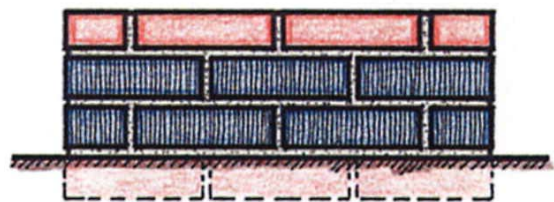

Always ensure that the type of DPC selected is suitable for the application.

2. Location of DPC's

DPC's are required in a number of places:

- ◆ At the base of external walls, not less than 150mm above ground level.
- ◆ Similarly at the base of internal walls that are built off foundations rather than the ground floor slab.
- ◆ Vertically at jambs to openings in external cavity walls.
- ◆ Horizontally below window sills and door thresholds.
- ◆ Below copings and cappings to freestanding, retaining and parapet walls and chimney stacks.

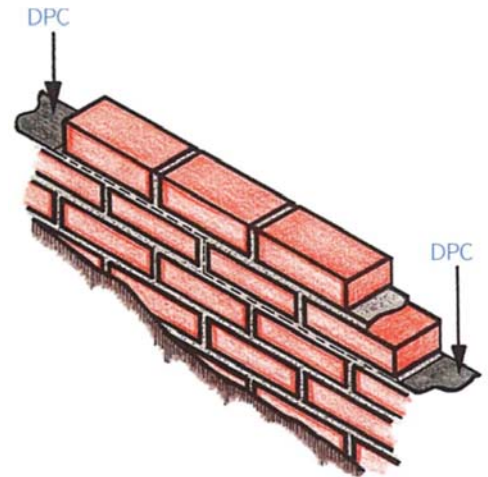

On sloping sites the DPC may need to be stepped as shown.

If a window or door frame is to be fixed after the opening is formed, the vertical DPC should project beyond the edge of the brickwork by about 10mm so as to make contact with the frame and the DPC should project a minimum 25mm into the cavity beyond the closer.

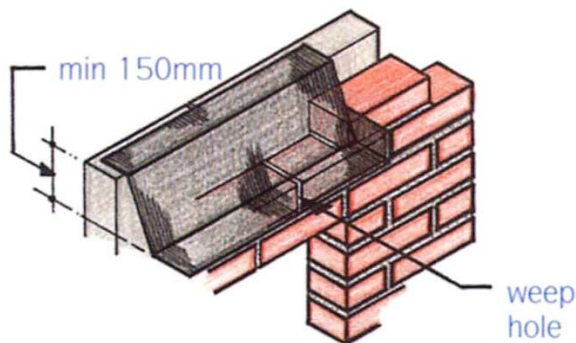
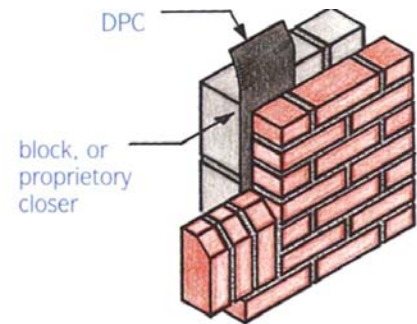

A horizontal DPC bridging over an opening in an external cavity wall is usually called a Cavity Tray. Any water penetrating the outer leaf of brickwork above the DPC will drain down the inside face of the wall and will be shed via 'weepholes' usually in the form of open vertical joints in the outer leaf. These may be fitted with a proprietary filter to reduce cementitious staining.

Typical DPC arrangement around an opening in a cavity wall.
(diagrammatic basic principles)

Remember to ensure the provision of sufficient weepholes.

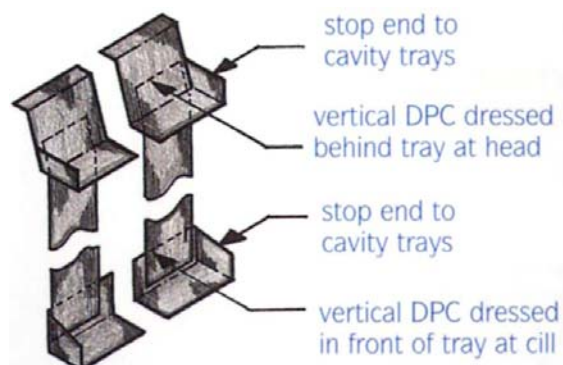

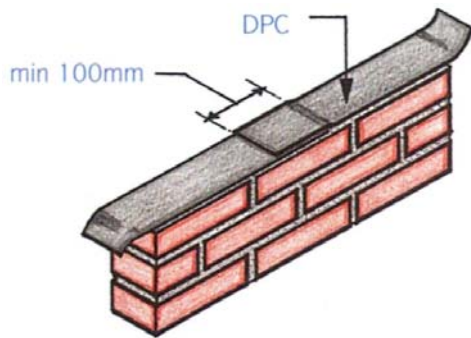

DPC's installed to prevent the downward passage of water should be lapped and bonded for a minimum of 100mm. (e.g. DPC's in parapet areas). Bonding of the DPC is not required for preventing the upward movement of water, but joints should still be lapped a minimum 100mm.

Having laid the mortar bed, the DPC should be carefully unrolled and pressed into the mortar by sliding a smooth brick along the DPC or by using a trowel. Care should be taken to use the correct width for the wall. The DPC should extend through the full thickness of the wall, and through each individual leaf of a cavity wall and should not be covered by pointing or rendering.

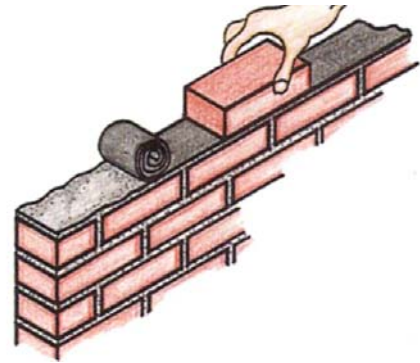

Always bed flexible DPC's on fresh, smooth mortar.

DPC's in cavity walls should not project into the cavity where mortar droppings may build up and lead to moisture penetration. It is recommended that DPC's project beyond the outside of the wall face by about 5mm.

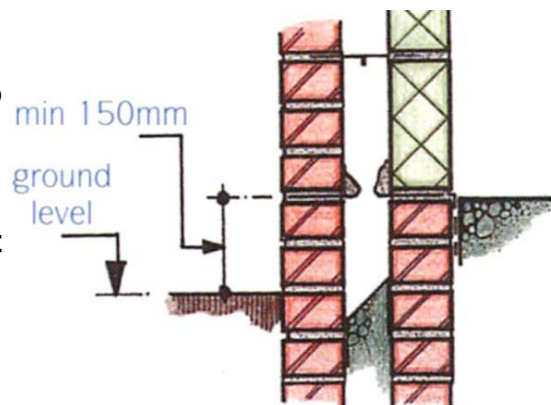

Where blocks are cut to form cavity closers the Smooth uncut surface should be placed towards the DPC at door and window openings. This will reduce the risk of the cut edge damaging the DPC. A mortar joint should be formed between the inner leaf and the DPC by buttering the face of the closer with mortar, before it is placed in position.

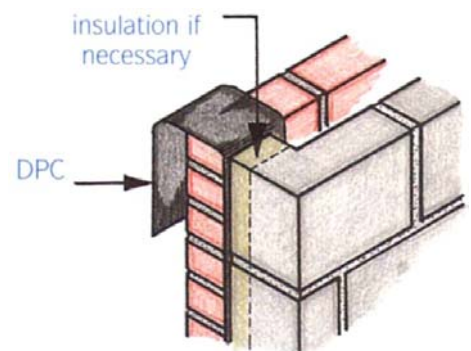

Key Points

Bed Flexible DPC's on fresh, smooth mortar.

Lap DPC's a minimum of 100mm

Do not cover the exposed edge of DPC's with mortar or render.

Extend DPC cavity trays beyond the ends of lintels and ensure stop ends are securely fixed.

Ensure provision of sufficient weepholes.

Use the correct type of DPC for the application.